

PRODUCT DETAILS

The DAB102M is a pressure switch controlled cast iron, self-priming centrifugal pressure pump with excellent suction capacity even when there are air bubbles in the water.

Particularly suited to water supply in domestic installations, small-scale agriculture, gardening and wherever self-priming operation is required.

DAB Jet pumps are renowned for their unique self priming and extraordinary deep suction capability; up to 8 metres at sea level.



APPLICATIONS

- Household water supply - medium to larger dwellings
- Light garden irrigation
- Water transfer
- Washing systems
- Pressure boosting

FEATURES

- Motor support in cast iron, technopolymer impeller, diffuser, Venturi tube and sand guard. Stainless steel adjustment rings.
- Carbon/ceramic mechanical seal.
- Asynchronous motor closed and cooled by external ventilation. Max Ambient temp 40 deg C
- Built-in thermal and current overload protection and a capacitor permanently on in the single-phase versions.



TECHNICAL DATA

OUTPUT POWER (KW)	0.75kW P2
MAX. HEAD [M]	53.8M
MAX. FLOW L/MIN	60 l/min
MAX PRESSURE	6 bar
CUT IN / CUT OUT	2.0 bar start / 4.0 bar stop
LIQUID TEMPERATURE	2 - 35 deg C
MOTOR	Asynchronous TEFC
MOTOR INSULATION	F Class insulation
MOTOR PROTECTION	In-built thermal overload
PROTECTION CLASS	IP44. Terminal board I.P.55

RATED VOLTAGE	220 - 240V 1Ph 50 Hz
RATED CURRENT	5.1A
CAPACITOR	16uF 450V
POWER CABLE	2m long 10 amp rated H05 flex 10 amp 3 pin plug
PUMP BODY	Cast iron 200 UNI ISO 185
INTERNALS	Technopolymer A
MECHANICAL SEAL	Carbon/Ceramic
AUTOMATIC OPERATION	Yes: Pressure switch control
PACKAGE DIMENSION	
GROSS WEIGHT (KG)	13.9 kg

CURVE

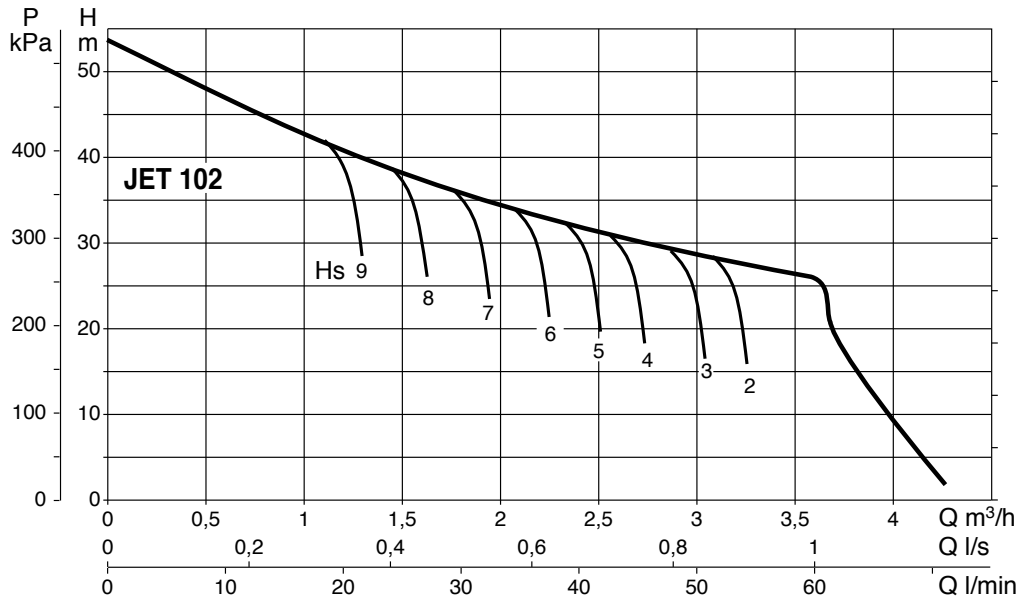

DIMENSIONS

A	414
A1	409
B	263
C	108
E	197
F	14
G	111
H	239
H	209
H	103
H3	144
I	Dia 9
DNA	1" GAS
DNM	1" GAS

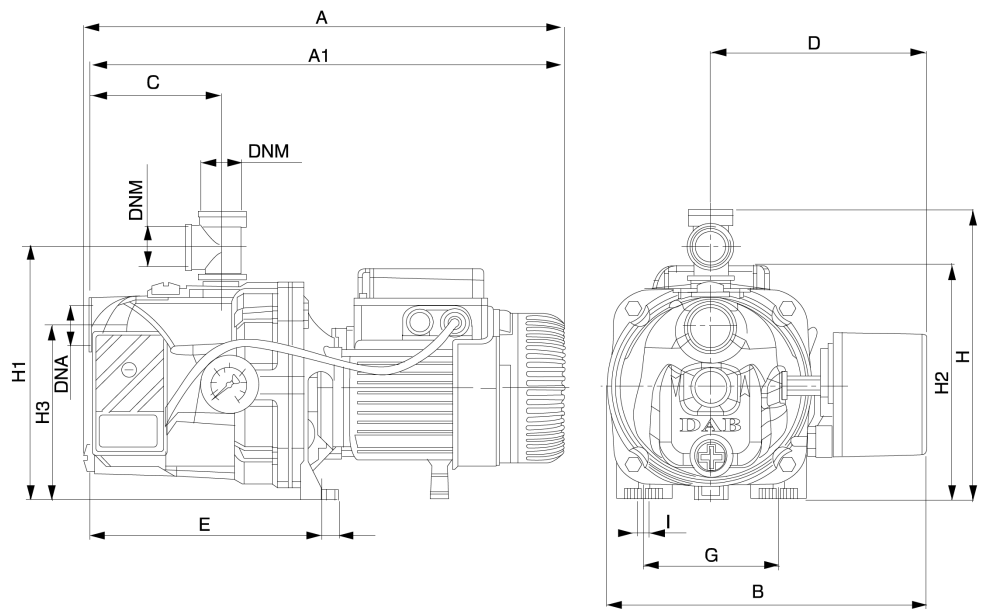

WARRANTY / CERTIFICATIONS

